

QSI LASER DIODE SPECIFICATIONS FOR APPROVAL

Customer :

Model : QL80R4S-A/B/C/D/E-S1

Tentative

Signature of Approval

Approved by _____

Checked by _____

Issued by _____

Approval by Customer



QSI Co., Ltd.

315-9, Chunheung-ri, Sungger-eup,
Cheonan-city, Chungnam, Korea 330-836

WWW.QSILaser.com

QL80R4S-A/B/C/D/E-S1

Tentative

Laser Diode

Quantum Semiconductor International Co., Ltd.

ver.4 May. 2009

◆ OVERVIEW

QL80R4S-A/B/C/D/E-S1 is a MOCVD grown 808nm band laser diode with quantum well structure. It's an attractive light source, with a typical light output power of 300mW for optoelectronic devices such as solid state laser pumping and medical use.

◆ APPLICATION

- Solid State Laser Pumping
- Medical Use
- Industrial Use

◆ FEATURES

- Wavelength : $\lambda_p = 808 \text{ nm}$
- Optical Output Power : 300mW (CW)
- Package Type : TO-18 ($\phi 5.6\text{mm}$)
- Polarization : TE (Electric Field Parallel to the Junction Plane)

◆ ELECTRICAL CONNECTION

Bottom View

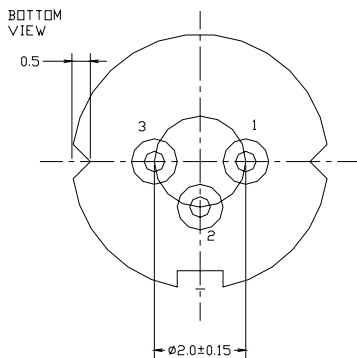

Pin Configuration

A	LD cathode, PD anode (Fig. 1)	QL80R4S-A
B	LD, PD anode (Fig. 2)	QL80R4S-B
C	LD anode, PD cathode (Fig. 3)	QL80R4S-C
D	LD cathode, No PD (Fig. 4)	QL80R4S-D
E	LD anode, No PD (Fig. 5)	QL80R4S-E

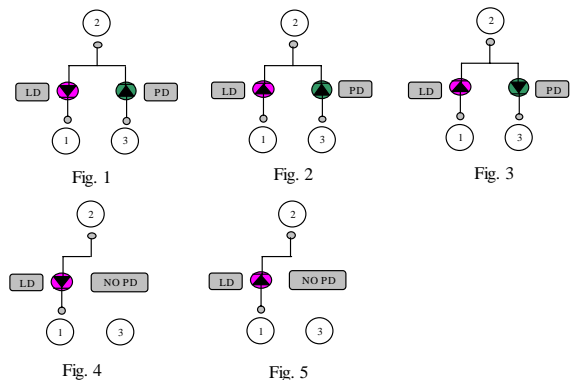

Tentative

◆ ABSOLUTE MAXIMUM RATING at Tc=25°C

Items	Symbols	Values	Unit
Optical Output Power	P	350	mW
Laser Diode Reverse Voltage	V	2	V
Photo Diode Reverse Voltage	V	30	V
Operating Temperature	Topr	-10 ~ +40	°C
Storage Temperature	Tstg	-40 ~ +85	°C

◆ ELECTRICAL and OPTICAL CHARACTERISTICS at Tc=25°C ¹⁾²⁾

Items	Symbols	Min.	Typ.	Max.	Unit	Condition
Optical Output Power	Po	-	300	-	mW	-
Threshold Current	Ith	-	80	100	mA	-
Operating Current	Iop	-	350	380	mA	Po=300mW
Operating Voltage	Vop	-	2.1	2.5	V	Po=300mW
Lasing Wavelength	λ_p	803	808	813	nm	Po=300mW
Beam Divergence ³⁾	$\theta $	-	8	12	deg	Po=300mW
	$\theta \perp$	-	35	45	deg	Po=300mW
Beam Angle	$\Delta\theta $	-	-	±3	deg	Po=300mW
	$\Delta\theta \perp$	-	-	±3	deg	Po=300mW
Monitor Current	Im	-	1.2	2.0	mA	Po=300mW
Polarization	TE mode					
Optical Distance	$\Delta X, \Delta Y, \Delta Z$	-	-	±60	μm	-

1) Initial Values 2) All above values are evaluated with QSI's measuring apparatus

3) Full Width at Half Maximum

NOTICE : QL80R4S-A/B/C/D/E-S1 to be operated on APC circuit.

The above product specifications are subject to change without notice.

◆ PACKAGE DIMENSION

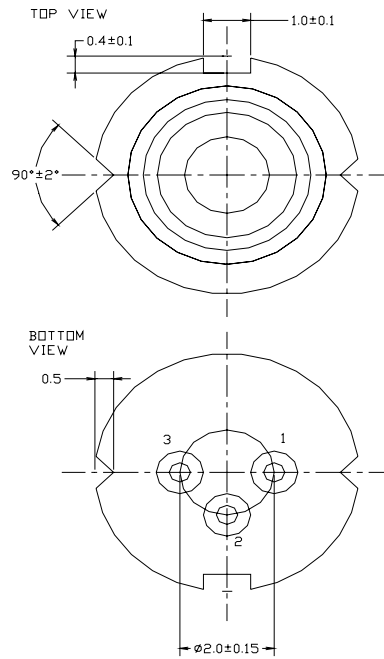
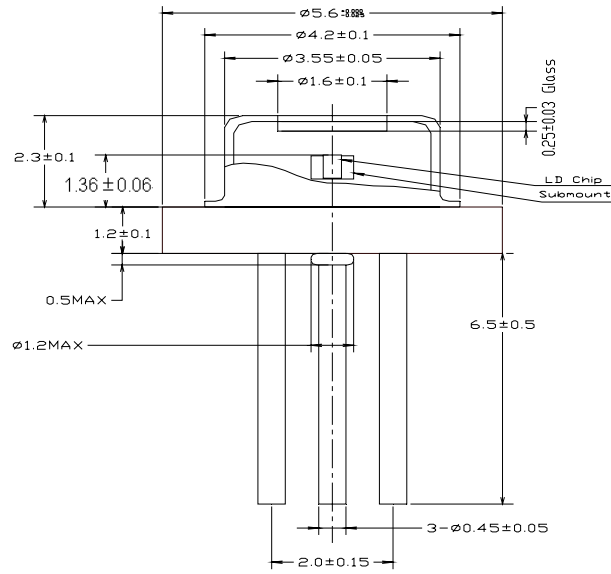

◆ PACKING

